

ENGLISH VERSION

CONTENTS

	Page
PREFACE	2
FEATURES	2
PRECAUTIONS	3
MAJOR OPERATING CONTROLS AND THEIR FUNCTIONS	4
SYSTEM CONNECTION	9
OPERATING PROCEDURE	10
A. VIDEO SECTION	10
B. AUDIO SECTION	16
SPECIFICATIONS	17
STANDARD ACCESSORIES	17
OPTIONAL ACCESSORIES	17



CAUTION
RISK OF ELECTRIC SHOCK
DO NOT OPEN



CAUTION: TO REDUCE THE RISK OF ELECTRIC SHOCK, DO NOT REMOVE COVER (OR BACK). NO USER-SERVICEABLE PARTS INSIDE. REFER SERVICING TO QUALIFIED SERVICE PERSONNEL.



The exclamation point within an equilateral triangle is intended to alert the user to the presence of important operating and maintenance (servicing) instructions in the literature accompanying the appliance.



The lightning flash with arrowhead symbol, within an equilateral triangle, is intended to alert the user to the presence of uninsulated "dangerous voltage" within the product's enclosure that may be of sufficient magnitude to constitute a risk of electric shock to persons.

The serial number of this product may be found on the bottom of the unit.

You should note the serial number of this unit in the space provided and retain this instructions as a permanent record of your purchase to aid identification in the event of theft.

Model No. WJ-MX10

Serial No. _____

WARNING: TO PREVENT FIRE OR SHOCK HAZARD, DO NOT EXPOSE THIS APPLIANCE TO RAIN OR MOISTURE.

PLEASE READ FOLLOWING INSTRUCTION IF YOUR POWER SOURCE VOLTAGE IS MORE THAN 200V.

WARNING

**THIS APPARATUS MUST BE EARTHED.
IMPORTANT**

Blue:	Neutral
Brown:	Live

As the colours of the wires in the mains lead of this apparatus may not correspond with the coloured markings identifying the terminals in your plug proceed as follows.

The wire which is coloured green-and-yellow must be connected to the terminal in the plug which is marked by the letter E or by the safety earth symbol  or coloured green or green-and-yellow.

The wire which is coloured blue must be connected to the terminal which is marked with the letter N or coloured black.

The wire which is coloured brown must be connected to the terminal which is marked with the letter L or coloured red.

THIS APPARATUS MUST BE EARTHED.

To ensure safe operation the three-pin plug supplied must be inserted only into a standard three-pin power point which is effectively earthed through the normal household wiring. Extension cords used with the equipment must be three-core and be correctly wired to provide connection to earth. Wrongly wired extension cords are a major cause of fatalities.

The fact that the equipment operates satisfactorily does not imply that the power point is earthed and that the installation is completely safe. For your safety, if in any doubt about the effective earthing of the power point, consult a qualified electrician.

This model conforms to the EC directive (for radio interference) 82/499/EEC.

This apparatus was produced to BS 800:1983.

PREFACE

The Panasonic WJ-MX10 Production Mixer is designed to mix or wipe any two video signals which are not even synchronized with each other, like video output signals from a video tape recorder.

There are two input sources, SOURCE 1 and SOURCE 2, and the video signal to VIDEO 1 may be processed using digital technology.

A superimpose feature is standard on the WJ-MX10. The superimpose source is selectable from VIDEO 1, VIDEO 2 or EXT CAMERA. The SYNC OUT terminal on this mixer enables to connect a black and white camera with the EXT CAMERA IN connector allowing the camera to be used for superimposing.

Background colour can be chosen from eight colours, including black and white. The WV-KB12 (Wired Keyboard-type Character Generator) is an optional accessory for making titles, featuring a scroll function. Additionally special effects such as shadowing of titles and edging of titles are also included.

Fade-in/fade-out is possible for three input sources, VIDEO, AUDIO and TITLE, independently or in any combination. One colour from eight colours is selectable as background colour for the video fade function.

By combining the use of the wipe selector buttons, up to 17 wipe patterns can be created. Wipe pattern positioning for circle and square within the TV screen, is easily accomplished using the built-in joystick positioner.

A built-in audio mixer enables audio mixing of signal input to AUDIO 1, AUDIO 2, AUX or MIC in stereo (except MIC). An audio check can be done by using the headphone output and audio level indicators. The volume level of the headphone can be adjusted with independent control.

FEATURES

- **BUILT-IN FRAME SYNCHRONIZER**
any two PAL-standard video sources.
- **SPECIAL EFFECTS — MOSAIC, PAINT, STILL, STROBE**
Using the built-in frame memory, special video effects are available for maximum variety in video creativity.
- **SUPERIMPOSE**
Input signals from VIDEO 1, VIDEO 2 and EXT CAMERA can be superimposed on the picture.
- **17 WIPE PATTERNS AND JOYSTICK POSITIONER**
In combination with the wipe pattern buttons, up to 17 wipe patterns are available. The joystick positioner allows free positioning of the circle and square of the wipe patterns.
- **AUDIO MIXING**
including a microphone. The front panel audio level meters are conveniently used for visual confirmation of the audio level.
- **FADE FUNCTION**
Fade-in and fade-out of Audio, Video and Video Titles can be accomplished separately or in any combination to meet all requirements in video tape production.
- **VIDEO TITLE**
The WV-KB12 Keyboard-type Character Generator is an optional title producer designed for connection to this Production Mixer. It will allow quick and easy title setting and features an eight-page memory that will hold titles produced.

PRECAUTIONS

The WJ-MX10 is a sensitive, high quality instrument and should be regarded as such. Because it is an electrical device, the danger of electric shocks exists if it is used carelessly.

DON'T

DO'S

- x Do not attempt to disassemble the instrument. In order to prevent electric shock, do not remove screws or covers. There are no user-serviceable parts inside.



- Do refer all servicing to qualified service personnel.

- x Do not abuse the instrument. Avoid striking, shaking, etc. It could be damaged by improper handling or storage.



- Do handle the instrument with care.

- x Do not use strong or abrasive detergents when cleaning the instrument body.



- Do use a dry cloth to clean the instrument when dirty. In case the dirt is hard to remove.

- x Do not expose the instrument to water or moisture, and do not operate it in wet areas if it is wet.



- Do take immediate action if ever the instrument does become wet. Turn the power off and refer servicing to qualified service personnel. Moisture can damage the instrument and also create the danger of electric shock.

- x Do not use the instrument in an extreme environment where high temperature or high humidity exist.



- Use the instrument under conditions where temperatures are within 0°C — 40°C, and humidity is below 90%.

MAJOR OPERATING CONTROLS AND THEIR FUNCTIONS

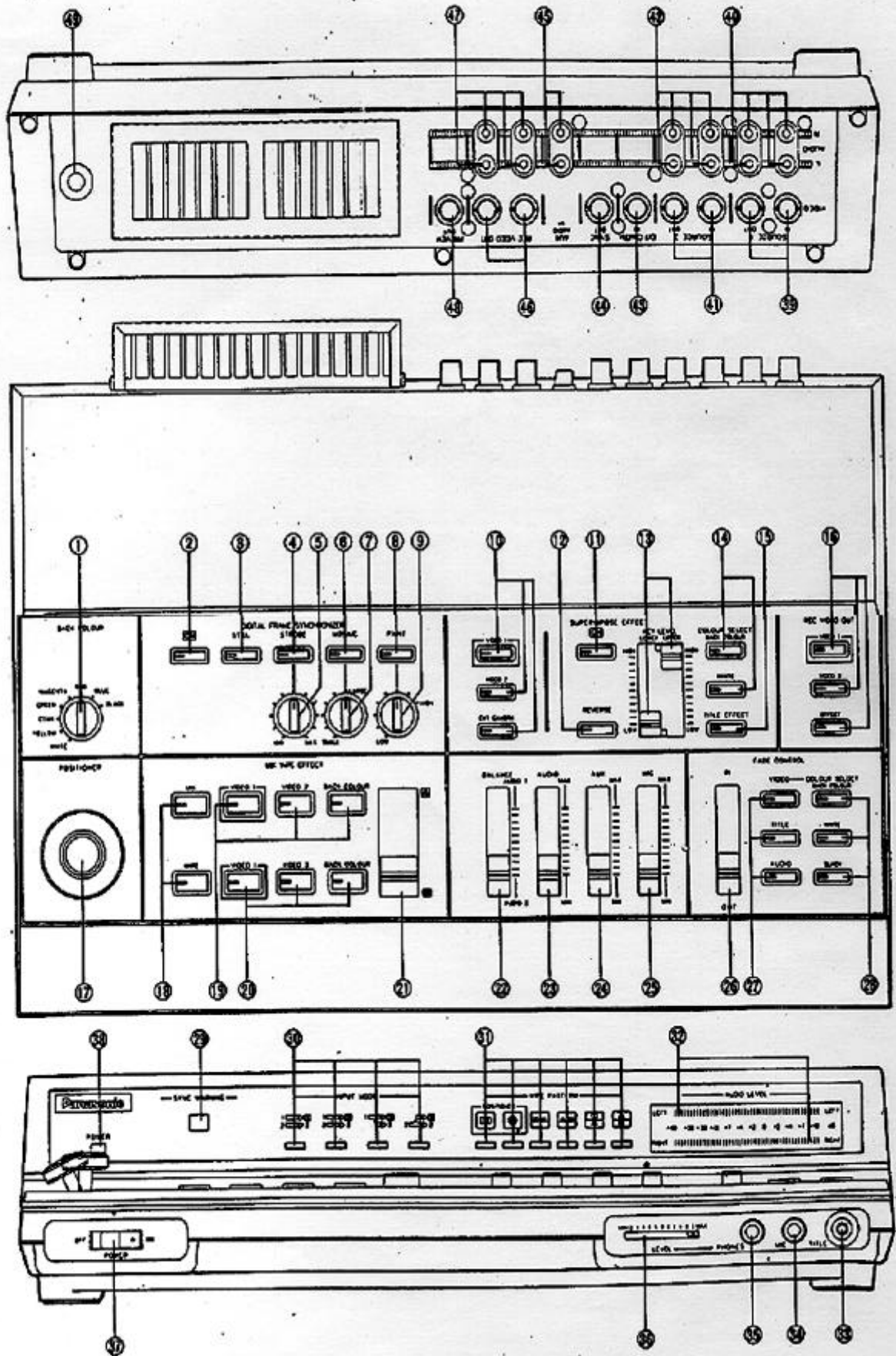

1. Back Colour Selection Switch (BACK COLOUR)

This control is used to select the background colour for MIX, WIPE, SUPERIMPOSE and VIDEO FADER operations.

One out of the following eight background colours can be chosen: White, Yellow, Cyan, Green, Magenta, Red, Blue and Black.

2. Digital Effect ON/OFF Switch (ON)

This switch is the Master ON/OFF switch for the digital effects, such as STILL, STROBE, MOSAIC and PAINT

Note: The digital effects are available only for VIDEO 1 as indicated in the box, and not for VIDEO 2.

3. Still ON/OFF Switch (STILL)

This switch is used to freeze the VIDEO 1 picture. Pressing this switch once, the VIDEO 1 image will freeze and the LED indicator in the switch lights. To return to a 'live' picture, press the switch once more. The LED indicator goes out.

4. Strobe ON/OFF Switch (STROBE)

This switch is used to obtain a strobe effect of the VIDEO 1 picture.

Pressing this switch once, strobe effects are applied to the VIDEO 1 image and the LED indicator in the switch lights. The time interval of the strobe effect can be changed by turning the Strobe Time Interval control (3).
To return to a normal picture, press the switch once more. The LED indicator goes out.

5. Strobe Time Interval Control (MIN/MAX)

Turning this control, the time interval of the strobe effect can be freely adjusted from approx. 0.2 to 2 seconds.

6. Mosaic ON/OFF Switch (MOSAIC)

This switch is used to obtain a mosaic effect of the VIDEO 1 picture.

Pressing this switch once, a mosaic effect is applied to the VIDEO 1 image and the LED indicator in the switch lights. To return to a normal picture, press the switch once more. The LED indicator goes out.

7. Mosaic Size Selection Control (SMALL/LARGE)

The mosaic size can be changed in six steps by using this control.

8. Paint ON/OFF Switch (PAINT)

This switch is used to obtain an oil-paint touch effect for the VIDEO 1 picture.

Pressing this switch once, an oil paint touch effect is applied to the VIDEO 1 image and the LED indicator in the switch lights. To return to a normal picture, press the switch once more. The LED indicator goes out.

9. Paint Graduation Selection Control (LOW/HIGH)

The graduation of paint effect can be changed in 8 steps (1 bit to 8 bits).

10. Source Selection Switches (SOURCE, VIDEO 1/VIDEO 2/EXT CAMERA)

These three switches are used to select the source for the image to be superimposed as follows:

VIDEO 1: The video signal fed to either the SOURCE 1 (1) or SOURCE 2 (2) connector on the rear panel, as selected by the Input Mode Selection switches (3) and the digital frame synchronizer, is selected.

VIDEO 2: The video signal fed to either the SOURCE 1 (1) or SOURCE 2 (2) connector on the rear panel, as selected by the Input Mode Selection switches (3), is selected.

EXT CAMERA: The video signal fed to the EXT CAMERA IN connector (4) on the rear panel is selected.

11. Superimpose ON/OFF Switch (ON)

This is the master ON/OFF switch for the superimpose function.

This switch is used to select the polarity of the superimposed key signal.

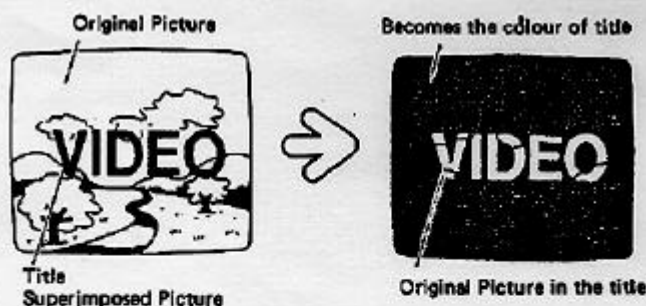

13. Key Level Controls (KEY LEVEL, LOWER, UPPER)

These two controls are used to adjust the luminance level of the key signal for lower level (black) and upper level (white), respectively for clear superimposed pictures.

Refer to step 9 of A-2 "SUPERIMPOSE" of the Operating Procedures.

14. Colour Selection Switches (BACK COLOUR, WHITE)

These 2 switches are used to select the colour of the superimposed titles, either white or the background colour selected by the Back Colour Selection switch (1).

15. Title Effect Switch (TITLE EFFECT)

By depressing this switch, the superimposed titles can be changed as follows:

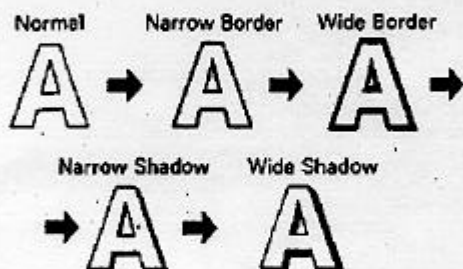
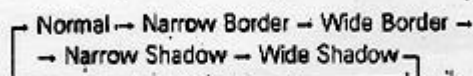

16. Recording Video Output Selection Switches (REC VIDEO OUT, VIDEO 1/VIDEO 2/EFFECT)

These switches are used to select the output video signal of the REC VIDEO OUT connectors on the rear panel as follows.

VIDEO 1: The video signal fed to either the SOURCE 1 or SOURCE 2 connector on the rear panel, as selected by the Input Mode Selection switches and the digital frame synchronizer, is selected.

panel, as selected by the Input Mode Selection switches, is selected.

EFFECT: The special effects video signal (superimpose, wipe/mix or fade) is selected.

17. Joystick Positioner (POSITIONER)

The position of the circle and square wipe patterns as selected using the Wipe Pattern Selection switches can be freely set using this joystick.

18. Mix/Wipe Mode Selection Switches (MIX/WIPE)

These two switches are used to select the Mix or Wipe mode.

19. A-bus Input Selection Switches (A, VIDEO 1/VIDEO 2/BACK COLOUR)

These switches are used to select the allocation of the video signal to the A-bus input.

VIDEO 1: The video signal fed to either the SOURCE 1 or SOURCE 2 connector on the rear panel, as selected by the Input Mode Selection switches and the digital frame synchronizer, is selected.

VIDEO 2: The video signal fed to either the SOURCE 1 or SOURCE 2 connector on the rear panel, as selected by the Input Mode Selection switches, is selected.

BACK COLOUR: The background colour signal set by the Back Colour Selection switch is selected.

20. B-bus Input Selection Switches (B, VIDEO 1/VIDEO 2/BACK COLOUR)

These switches are used to select the allocation of the video signal to the B-bus input in addition to the A-bus Input Selection switches.

21. Wipe/Mix Lever (A, B)

In the wipe mode, moving this lever from A to B will increase the portion of the B input, and vice versa. In the mix mode, video images are switched between A and B.

22. Balance Control (BALANCE, AUDIO 1/AUDIO 2)

This control is used to balance the mixed audio signal fed to SOURCE 1 (AUDIO 1) input connector and the signal fed to SOURCE 2 (AUDIO 2) input connector on the rear panel.

23. Audio level Control (AUDIO, MAX/MIN)

This is the overall attenuator for the mixed AUDIO 1 and AUDIO 2 sound.

24. Auxiliary Audio Level Control (AUX, MAX/MIN)

This is the input attenuator for the auxiliary audio signal fed to the AUX AUDIO IN connectors on the rear panel.

fed to the MIC input jack.

26. Fade Lever (IN/OUT)

Moving this lever from OUT to IN, fade-in of the sound takes place. Fade-out is accomplished by moving the lever from IN to OUT.

27. Fade Control Switches (VIDEO, TITLE, AUDIO)

These switches are used to select the fade mode as follows.

	VIDEO	TITLE	AUDIO
VIDEO fade	ON	OFF	OFF
TITLE fade	OFF	ON	OFF
AUDIO fade	OFF	OFF	ON
VIDEO & AUDIO fade	ON	OFF	ON
VIDEO & TITLE fade	ON	ON	OFF
TITLE & AUDIO fade	OFF	ON	ON
VIDEO & TITLE & AUDIO fade	ON	ON	ON

28. Colour Selection Switches (COLOUR SELECT, BACK COLOUR/WHITE/BLACK)

These switches are used to select the colour for the fade-out mode as follows.

BACK COLOUR: The back colour signal set by the Back Colour Selection switch is selected.

WHITE: The image will fade out in white.

BLACK: The image will fade out in black.

29. Sync Warning Indicator (SYNC WARNING)

This LED indicator shows the sync conditions as follows.

Green: The GEN-LOCK sync mode is selected and the sync generator inside the unit is synchronizing the signal with the VIDEO 2 signal.

Orange (amber): The Internal sync mode is selected and no video signal is supplied to the VIDEO 2 channel.

Red: The synchronization is disturbed or unstable. Even if the VIDEO 2 signal is supplied, the sync generator inside cannot synchronize the signal properly because of noise in the VIDEO 2 signal.

Note: If the indicator colour of the indicator changes, check the SOURCE signal for the VIDEO 2 signal whether the synchronization error still exists.

30. Input Mode Selection Switches (INPUT MODE)

These 4 switches are used to select the input mode as follows:

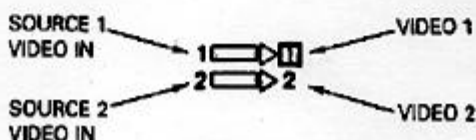

The signal, being passed through the digital frame synchronizer, and the SOURCE 2 video signal is used for the VIDEO 2 signal.

 The SOURCE 1 video signal is used for the VIDEO 2 signal and the SOURCE 2 video signal is used for the VIDEO 1 signal, the latter being passed through the digital frame synchronizer.

 The SOURCE 1 video signal is used for both the VIDEO 1 and VIDEO 2 signal.

 The SOURCE 2 video signal is used for both the VIDEO 1 and VIDEO 2 signal.

Caution: Do not change the setting of these switches during recording, as this may result in synchronization error.

31. Wipe-Pattern Selection Switches (WIPE PATTERN)

The wipe pattern can be selected as follows.



Square and circle wipe can be selected with the two switches on the left. Position in this case is done through use of the Joystick Positioner ⑩.

Through combined use of the four switches on the right, the following wipe patterns can be selected. Please note that positioning in this case is not effective.

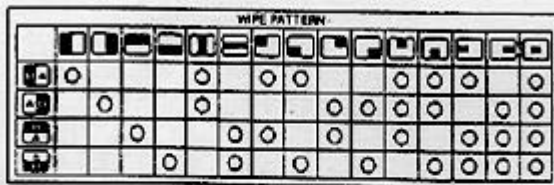

32. Audio Level Indicator (AUDIO LEVEL)

These LED indicators show the output level for the left and right channels, respectively.

33. Title Input Connector (TITLE)

This connector is used to connect the optional Character Generator WV-KB12.

- ①: Character IN
- ②: Not used
- ③: Ground
- ④: Not used
- ⑤: Sync out
- ⑥: Not used
- ⑦: Ground
- ⑧: +9V OUT
- ⑨: Ground
- ⑩: Not used

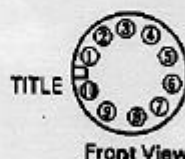

Caution: When WV-KB12 is used with this unit, the following functions of the WV-KB12 are

1. Stop/start display
2. Title colour setting
3. Title page display

34. Microphone Input Jack (MIC)

This jack is used to connect a microphone with a tip-ring-sleeve or tip-sleeve type phone plug.

35. Headphone Jack (PHONES)

This jack is used to connect a headphone and the output level can be adjusted by the Headphone Level Control ⑨.

36. Headphone Level Control (LEVEL)

This is level control for headphone output.

37. Power ON/OFF Switch (POWER ON/OFF)

38. Power Indicator (POWER)

39. Source 1 Video Connectors (SOURCE 1, VIDEO IN/OUT)

A 1.0 Vp-p/75 ohm composite video signal should be supplied to the input (IN) connector. Connecting coaxial cables with BNC connectors to the output (OUT) connector, the high impedance video loop is automatically selected. At all other times, the terminals are automatically terminated by 75 ohms.

Note:

- (1) If the input video signal does not meet with the PAL colour standard or the CCIR B/W standard video signal, this could cause a disturbance of synchronization.
- (2) In case the S/N ratio of the input signal is very low, this may be reflected in a low-quality picture.
- (3) If the input video signal is very jittery, such as in case of the VTR playback picture, this could cause a disturbance of synchronization or colour.
In case the video signal from the VTR and that of the camera is to be mixed, it is recommended to select the camera signal for the VIDEO 2 signal by the Input Mode Selection switches ④.

40. Source 1 Audio Connector (SOURCE 1, AUDIO L/R)

-10 dB/15 kohms audio signals for the SOURCE 1 should be supplied to these input (IN) connectors. The input audio signals can be taken out from the output (OUT) connectors with a high impedance loop.

41. Source 2 Video Connector (SOURCE 2, VIDEO IN/OUT)

The IN connector accepts a 1.0 Vp-p/75 ohm composite video signal.

Connecting coaxial cable with a BNC connector to the IN connector, the cable is automatically terminated by 75 ohms.

Note:

- (1) If the input video signal does not meet the PAL colour standard or the CCIR B/W standard, this could cause synchronization error.
- (2) In case the S/N ratio of the input signal is very low, this may be reflected in a low-quality picture.
- (3) If the input video signal is very jittery, such as a picture played back on a VTR, synchronization or colour error may appear.
In case the video signal from the VTR and that of the camera is to be mixed, it is recommended to select the camera signal for the VIDEO 2 signal by the Input Mode Selection switches ④.

42. SOURCE 2 Audio Connectors (SOURCE 2, AUDIO L/R)

The IN connectors accept a -10dB/15 kohm audio signal.

The input audio signals can be taken out from the output (OUT) connectors with a high impedance loop.

43. External Camera Input Connector (EXT CAMERA IN)

For the key signal in the superimpose mode, this connector accepts a 1.0 Vp-p/75 ohm composite video signal, which is synchronized with the sync output signal provided at the SYNC OUT connector ④.

44. Sync Output Connector (SYNC OUT)

A 1.0 Vp-p/75 ohm negative polarity composite sync signal is provided at this connector for synchronization of an external camera.

45. Auxillary Audio Input Connectors (AUX AUDIO IN)

Accept -10dB/15 kohm audio signals from an external audio source.

46. Recording Video Output Connectors (REC VIDEO OUT 1/2)

A 1.0 Vp-p/75 ohm composite video signal, as selected by the Recording Video Output Selector switches ④, is provided at these connectors.

47. Recording Audio Output Connectors)

-8dB/1 kohm audio signals for recording are supplied at these connectors.

48. Preview Output Connector (PREVIEW OUT)

A 1.0 Vp-p/75 ohm composite video signal of the EFFECT (all effect) image is provided at this connector.

49. Power Cord

Preparing the Character Generator (optional)

- Mount the optional Character Generator WV-KB12 onto the Character Generator mounting base.

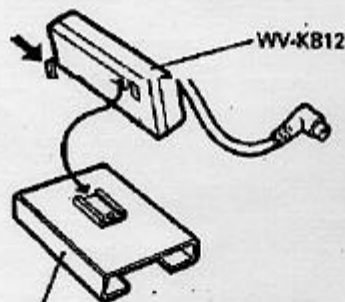

Mounting Base for Character Generator

- Connect the cable of the WV-KB12 to the Title Input Connector ④.

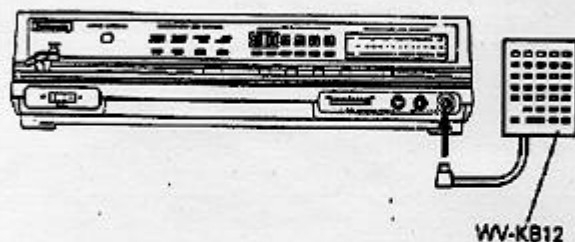

SYSTEM CONNECTION

Caution: Keep the POWER ON/OFF switch turned OFF while making the connections.

1. Connect the coaxial cable with BNC connectors between the video output of the VTR, Video Disc Player, TV Tuner Output or Video Camera and the SOURCE 1 VIDEO IN connector on the rear panel of the Production Mixer.
2. Connect the audio cable with pin plugs between the audio output of the VTR, Video Disc Player, TV Tuner Output or Video Camera and the SOURCE 1 AUDIO IN connectors on the rear panel of the Production Mixer.
3. Connect the coaxial cable and audio cable for the SOURCE 2 inputs of the Production Mixer in the same manner as steps 1 and 2 above.
4. Connect the coaxial cable with BNC connectors between the video output of the external camera (B/W or colour camera for superimposing) and the EXT CAMERA IN connector of the Production Mixer.
5. Connect the coaxial cable with BNC connectors between the SYNC IN (GEN LOCK IN) connector on the external camera and the SYNC OUT connector of the Production Mixer.
6. If the Character Generator WV-KB12 (sold separately) is used, connect the 10-pin cable connector of the Character Generator to the TITLE connector of the Production Mixer.
7. If an auxiliary audio source is required, connect the audio cable with pin plugs between the audio output of the audio source (a CD Player, Tape Recorder or Record Player) and the AUX IN connectors of the Production Mixer.
8. If necessary, connect the microphone cable with a tip-ring-sleeve type or tip-sleeve type phono plug to the MIC input connector of the Production Mixer.
9. For previewing the image, connect the coaxial cable with BNC connectors between the PREVIEW OUT connector of the Production Mixer and the VIDEO IN connector of a video monitor.
10. For recording, connect the coaxial cables with BNC connectors between the REC VIDEO OUT connectors of the Production Mixer and the VIDEO IN connectors of the VTR and Video Monitor.
11. For recording, connect the audio cable with pin plugs between the REC AUDIO OUT connectors of the Production Mixer and the AUDIO IN connectors of the VTR and Video Monitor.

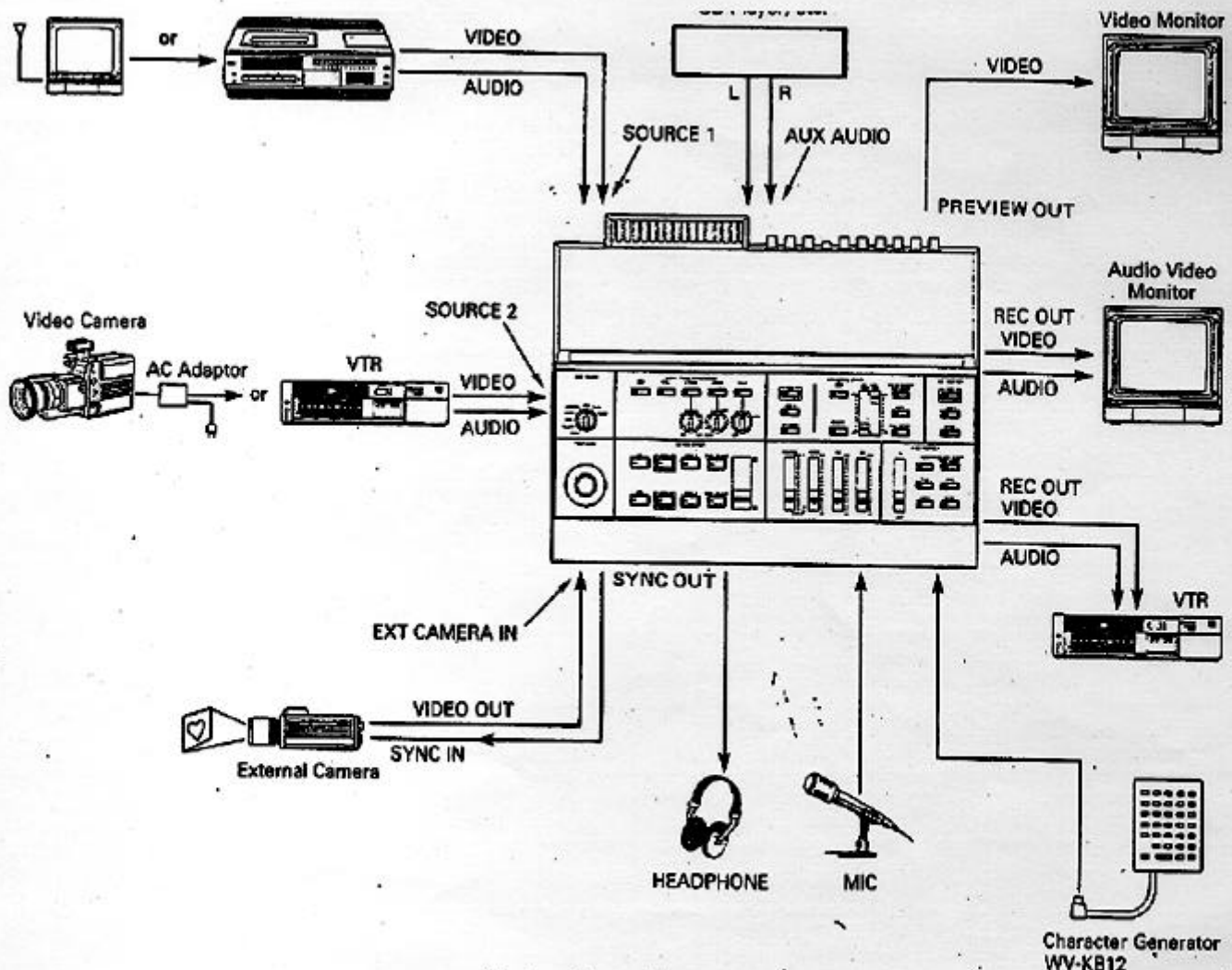

System Connections

OPERATING PROCEDURE



1. Make all necessary connections.
2. Turn ON the Production Mixer and all other equipment connected.
3. Prepare the script of the program.
4. Prepare all necessary title cards.



Note: Both the title cards with black letters on white or white on black can be used for the superimpose function.

5. Store all titles to be superimposed in the Character Generator WV-KB12 while referring to the operating instructions of the WV-KB12.



A. VIDEO SECTION

A-1 Digital Effects (whole areas)

- 1) Set the Input Mode Selection switch to  or .

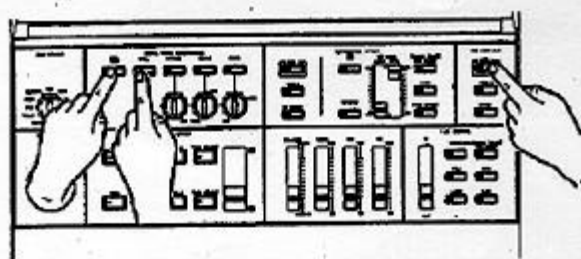
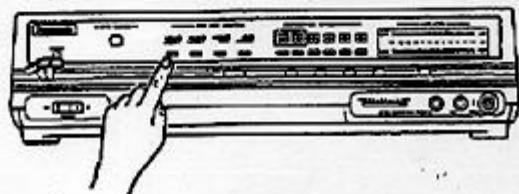
Note: In case you want to process the SOURCE 1 video signal with digital effects (e.g., Mosaic, Paint), select . Select  for the SOURCE 2 video signal.



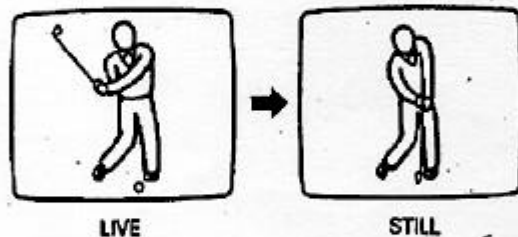

- 3) Press the Digital Effect ON/OFF switch .
- 4) Press the Still ON/OFF switch  once to freeze the picture.



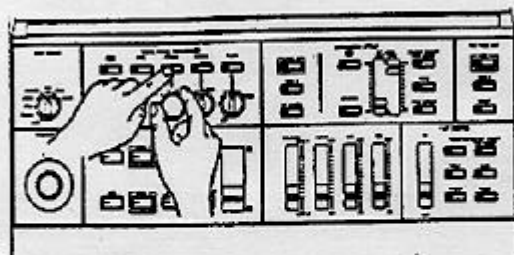

- 5) To return to a live picture, press the Still ON/OFF switch  once more.

- 6) Press the Strobe ON/OFF switch  once to obtain strobe effects. (This function can be much likened with still pictures played in slow motion of 0.2 to 2 second intervals.)



- 7) Adjust the Strobe Time Interval control  by turning it clockwise (MAX — slower) or counterclockwise (MIN — faster).



- 8) To return to a normal, live picture, press the Strobe ON/OFF switch  once more.
- 9) Press the Mosaic ON/OFF switch  once to obtain a

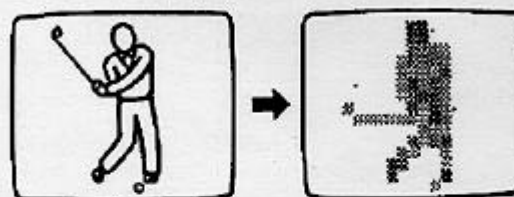
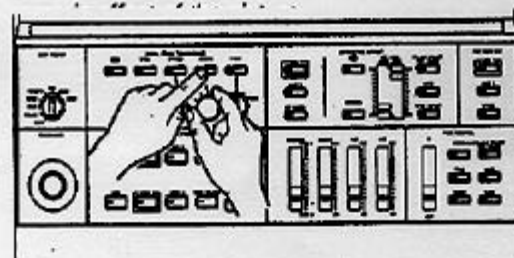

- 10) The mosaic size can be changed at will in 6 steps by turning the Mosaic Size Selection switch .

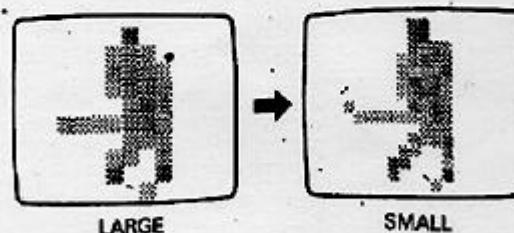

- 11) To return to a normal picture, press the Mosaic ON/OFF switch  once more.

- 12) Press the Paint ON/OFF switch ⑩ once to obtain an oil-paint touch effect on the picture.

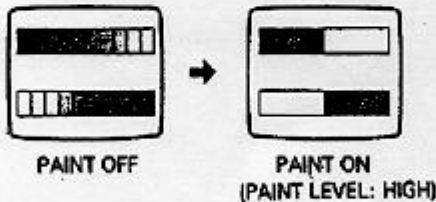
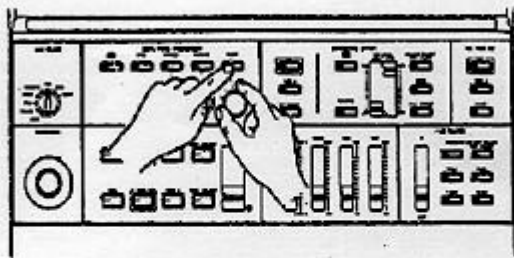

- 13) Select paint effect graduation by turning the Paint Graduation Selection control ⑪ clockwise (HIGH — 1 bit) or counterclockwise (LOW — 8 bits).



- 14) To return to a normal picture, press the Paint ON/OFF switch ⑩ once more.

A-2 Superimpose

- 1) Set the Input Mode Selection switch to ⑬ or ⑭.

Note: In case you want to process the SOURCE 1 video signal with digital effects (e.g., Mosaic, Paint), select ⑬. Select ⑭ for the SOURCE 2 video signal.

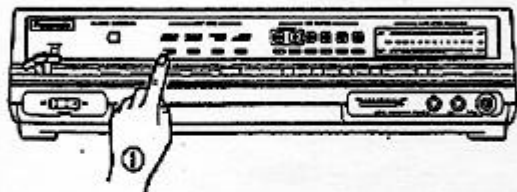

- 2) Press either the MIX or the WIPE switch of the Mix/Wipe Mode Selection switches ⑮.
- 3) Select the background image. Set Wipe/Mix lever to lower position (B) for B-bus image as background or upper position (A) for A-bus image as background. The source can be selected from the VIDEO 1, VIDEO 2 or BACK COLOUR for either position. In case BACK COLOUR is selected, set the Back Colour Selection switch to the desired colour.

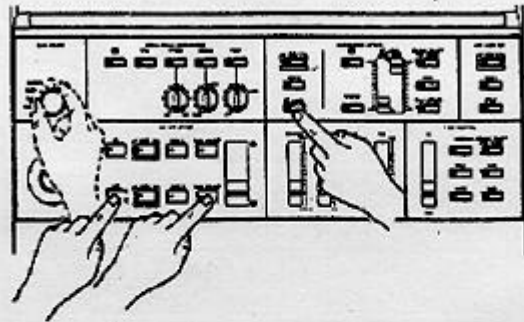

- 4) Select the key image source (the one to be superimposed) by pressing one of the Source Selection switches ⑲: VIDEO 1, VIDEO 2 or EXT CAMERA.

Note: In case the Character Generator is going to be used, this unit is enabled by connection its cable to the Title Input connector ⑳.

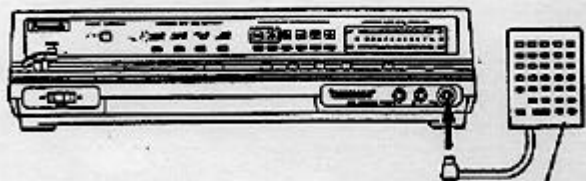

Character Generator WV-K812

- 5) Select the colour for the superimposed titles or characters. Press the BACK COLOUR or WHITE switch of the Colour Selection switches ⑳.

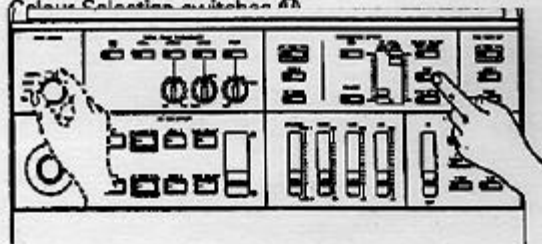

Caution: Do not simultaneously choose back colour for the A-bus (B-bus) and the colour for the superimpose function.

In case the back colour is selected for the superimpose function, set the Back Colour Selection switch ⑲ to the desired colour.

- 6) Press the Superimpose ON/OFF switch ⑰ once to enable the function.

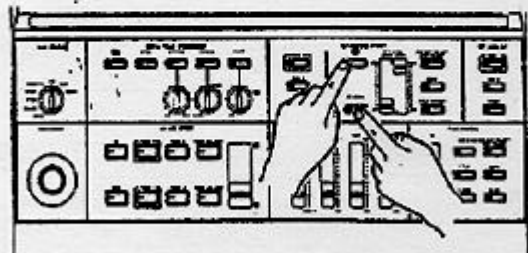

- 7) Select the polarity of the key signal to be superimposed by pressing the Reverse switch ⑩:

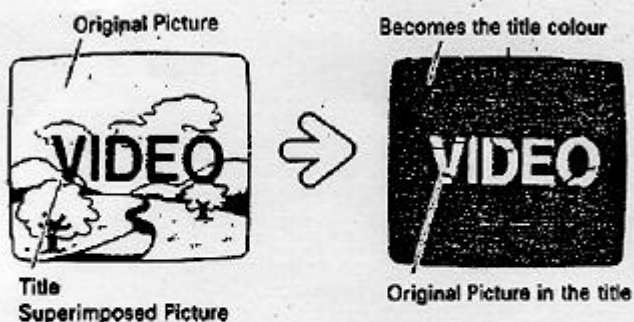

- 8) While observing the image on a video monitor, which is connected to the Preview Output connector ⑨, adjust the Key Level-control (LOWER/UPPER) ⑪ until a clear superimposed image is obtained.

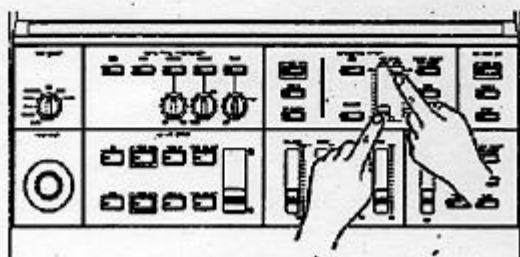

black, set the UPPER lever of the Key Level control to the HIGH end, and adjust the LOWER lever for a clear superimposed picture.



TITLE CARD

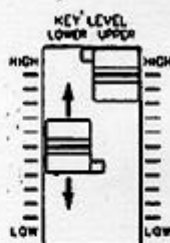

In case the title card is written with black on white, set the LOWER lever to the LOW end and adjust the UPPER lever for a clear superimposed picture.



TITLE CARD

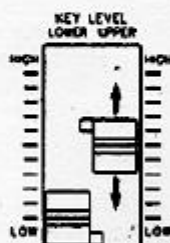

Note: When the optional Character Generator WV-KB12 is only used for the superimpose, set both levers to the LOW end.

- 9) If desired, select title edge enhancement by operating the Title Effect switch ⑬ as follows:

Normal → Narrow Border → Wide Border →
→ Narrow Shadow → Wide Shadow

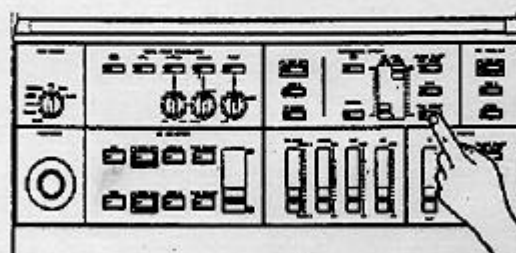
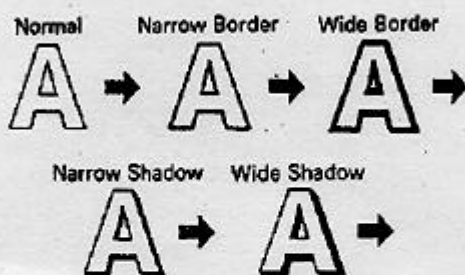

- 10) Depress the EFFECT switch on the Recording Output Selection Switches ⑭.

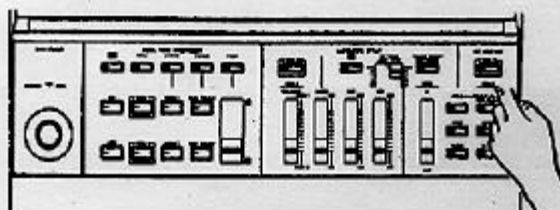

A-3 Mixing (Lap-dissolve)

- 1) Set the Input Mode Selection switch to ⑮ or ⑯.

Note: In case you want to process the SOURCE 1 video signal with digital effects (e.g., Mosaic, Paint), select ⑮. Select ⑯ for the SOURCE 2 video signal.

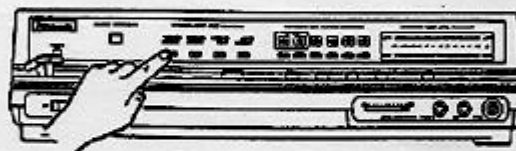

- 2) Press the Effect Switch of the Recording Output Selector switches ⑰.



3) Press the MiX switch of the Mix/Wipe Selection switches ①.

4) Select the source signal for A-bus and B-bus signals from the VIDEO 1, VIDEO 2 or BACK COLOUR.

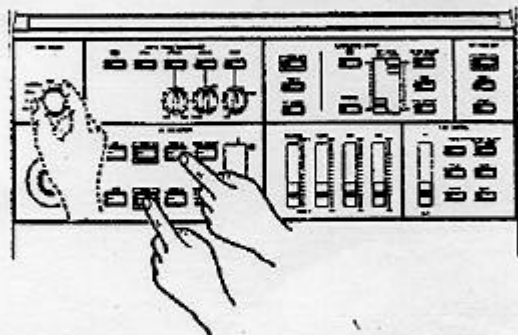

In case back.colour is selected, set the Back Colour Selection switch ② to the desired colour.

5) Confirm that the LED indicator of the VIDEO switch of the Fade Control switches ③ is off.

6) Operate the Wipe/Mix Lever ④ from A to B, or vice versa.

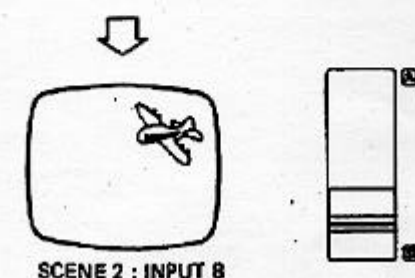
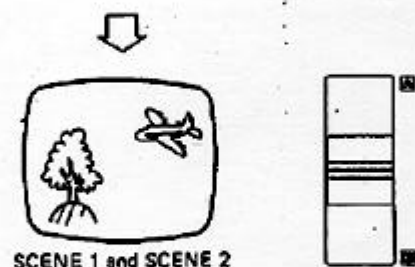
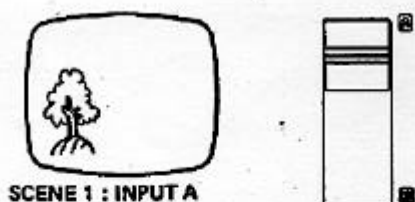
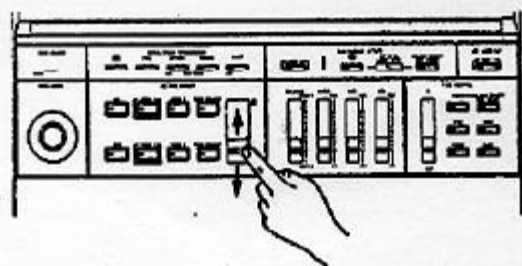

A-4 Wipe

1) Set the Input Mode Selection switch to ⑤ or ⑥.

Note: In case you want to process the SOURCE 1 video signal with digital effects (e.g., Mosaic, Paint), select ⑤. Select ⑥ for the SOURCE 2 video signal.

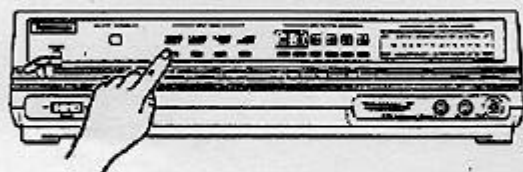

2) Press the Effect Switch of the Recording Output Selector switches ⑦.

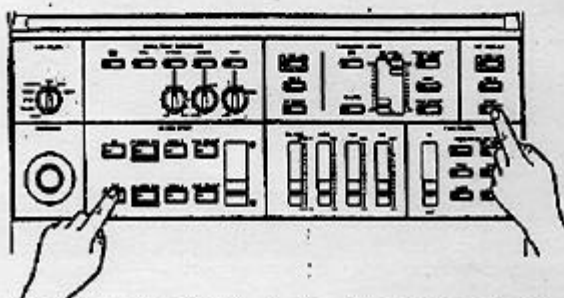

switches ⑧.

4) Select the desired wipe mode by pressing one of the Wipe Pattern Selection switches ⑨.

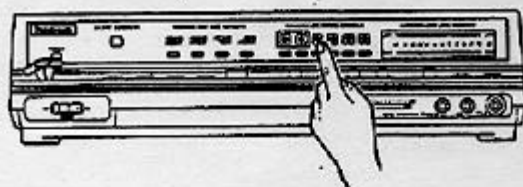

If Circle (⑩) or Square (⑪) wipe with positioner control is desired, press one of these switches on the left.



If another wipe mode is desired, to obtain the wipe mode press a combination of the switches according to the following table.

WIPE PATTERN											
	⑫	⑬	⑭	⑮	⑯	⑰	⑱	⑲	⑲	⑲	⑲
⑩	○			○		○		○	○	○	○
⑪		○		○				○	○	○	○
⑫			○		○		○		○	○	○

(E.g., for the ⑰ pattern, press switches ⑫ and ⑬ simultaneously.)

- 5) Select the source signal for A-bus and B-bus signals from the VIDEO 1, VIDEO 2 or BACK COLOUR.

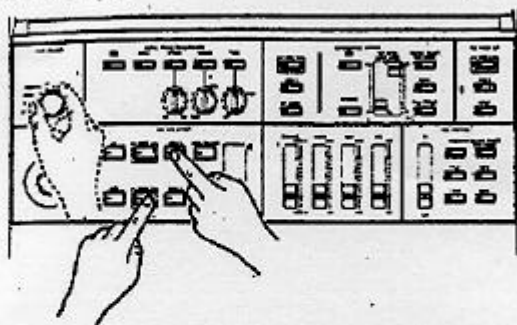

In case back colour is selected, set the Back Colour Selection switch ① to the desired colour.

- 6) Confirm that the LED indicator of the VIDEO switch of the Fade Control switches ② is off.
7) Operate the Wipe/Mix Level ③ from A to B, or vice versa.

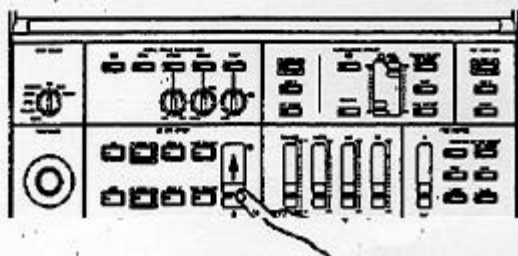

Input A



Wiped picture



Input B

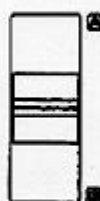
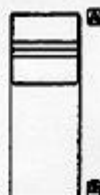

A-5 Fade-in and Fade-out

- 1) Set the Input Mode Selection switch to ④ or ⑤.

Note: In case you want to process the SOURCE 1 video signal with digital effects (e.g., Mosaic, Paint), select ④. Select ⑤ for the SOURCE 2 video signal.

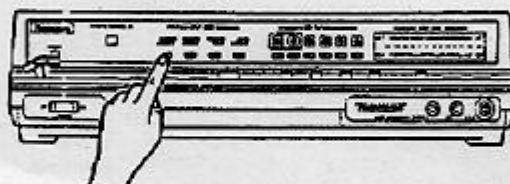

- 2) Press the Effect Switch of the Recording Output Selector switches ⑥.

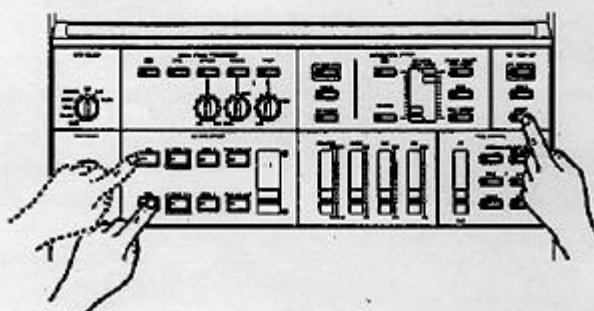

- 3) Press the WIPER or MIX switch of the Mix/Wipe Selection

- 4) Select the source signal for A-bus and B-bus signals from the VIDEO 1, VIDEO 2 or BACK COLOUR.

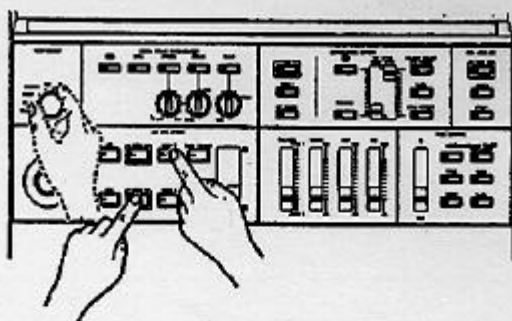

In case back colour is selected, set the Back Colour Selection switch ① to the desired colour.

- 5) Select the fade control mode by pressing one of the Fade Control switches ② as follows:

- Video Fade-in/out VIDEO switch
- Video & Title Fade-in/out VIDEO and TITLE switches
- Title Fade-in/out TITLE switch
- Video and Audio Fade-in/out' VIDEO and AUDIO switches
- Video, Title and Audio Fade-in/out VIDEO, TITLE and AUDIO switches

- 6) Select the colour you want to fade out by pressing the BACK COLOUR, WHITE or BACK switch.

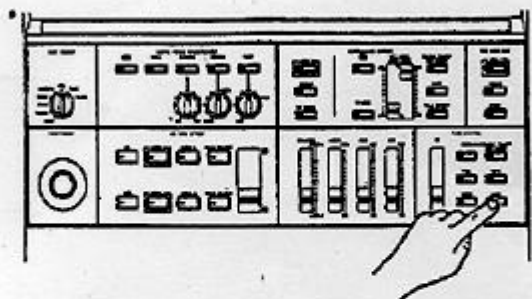

- 7) Operate the Fade lever from IN to OUT, or vice versa.

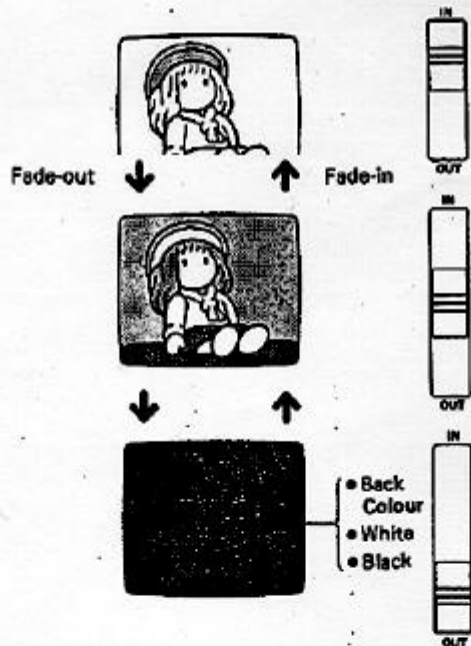
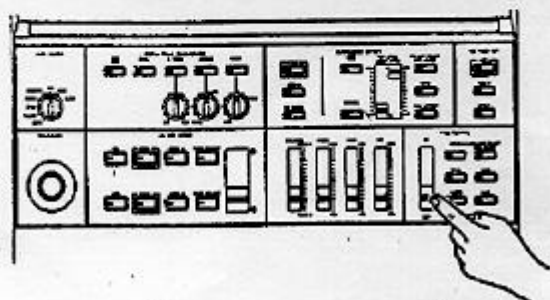

A-6 Digital and Mix/Wipe Effects

- 1) Set the Input Mode Selection switch to or .
- Note:** In case you want to process the SOURCE 1 video signal with digital effects (e.g., Strobe, Paint), select . Select for the SOURCE 2 video signal.

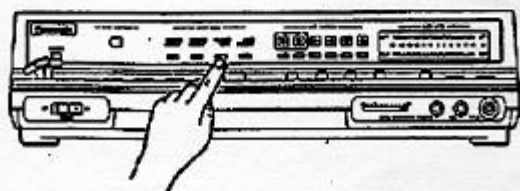

- 2) Press the Effect Switch of the Recording Output Selector switches .

- 3) Press the Digital Effect ON/OFF switch .

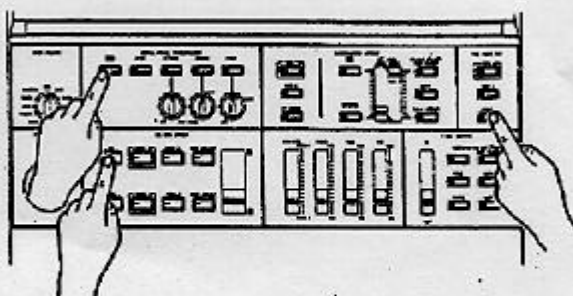

- 4) Press the MIX switch of the Mix/Wipe Selection switches .

- 5) Select VIDEO 1 and VIDEO 2 for the A-bus and B-bus in the Mix/Wipe Effect section.

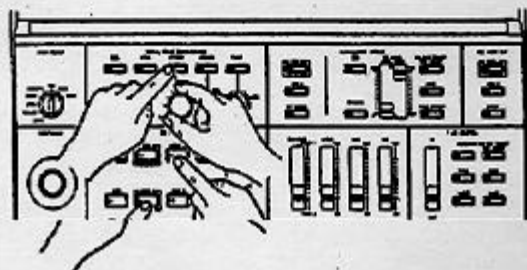

- 6) Press the Strobe ON/OFF switch and adjust the Strobe Timer Interval control .

- 7) Move the Wipe/Mix lever to the center position to obtain an after-image effect.

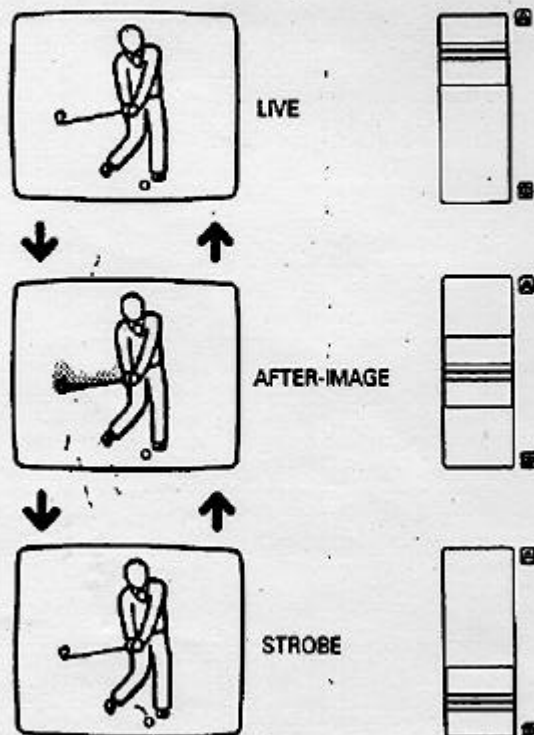

- 8) Press the Mosaic ON/OFF switch ⑥ and adjust the mosaic size using the Mosaic Size Selection switch ⑦.

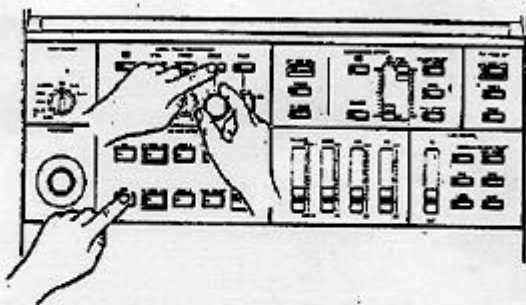

- 9) Press the WIPE switch of the Mix/Wipe Mode Selection switches ⑧.
- 10) Select Circle or Square wipe using one of the two left-hand switches of the Wipe Pattern Selection switches ⑨.

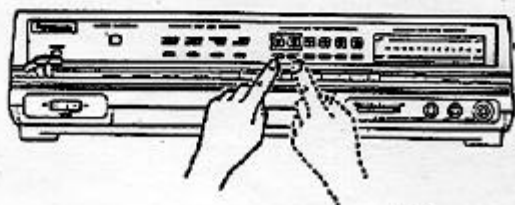

- 11) Operate the Wipe/Mix lever ⑩ for desired wipe size.



- 12) Operate the Joystick Positioner ⑪ to position the wipe position on the screen.

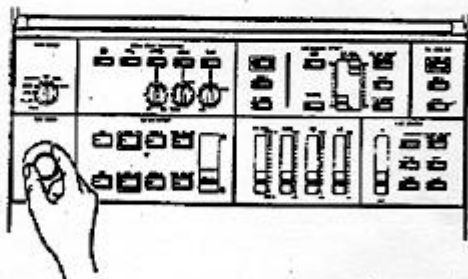

B. Audio Section

The following is a block diagram depicting the circuitry of the audio section.

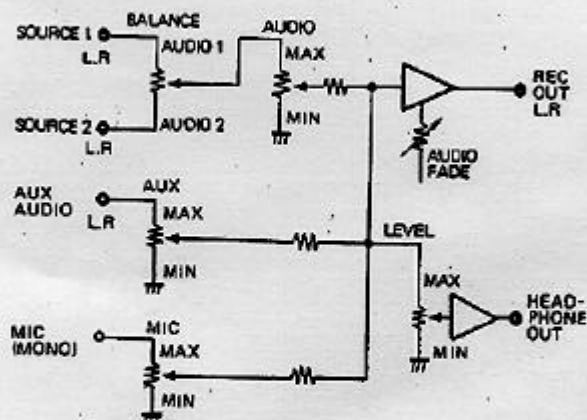

- 1) To select the SOURCE 1 audio signal for recording, set the Balance control ⑫ to the end position "AUDIO 1", and adjust the audio level by operating the Audio Level control ⑬.

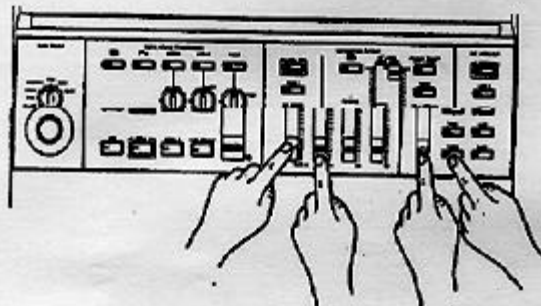

- 2) To mix the SOURCE 1 and SOURCE 2 audio signals, adjust the Balance control ⑫.
- 3) To mix the auxiliary audio signal for recording, adjust the AUX Level control ⑭.
- 4) To mix the microphone signal for recording, adjust the MIC Level control ⑮.
- 5) To fade in or fade out the audio signal, press the AUDIO switch of the Fade Selection switches ⑯ and operate the Fade Lever ⑰.
- 6) To adjust the headphone output level, operate the Head-phone Level control ⑱.

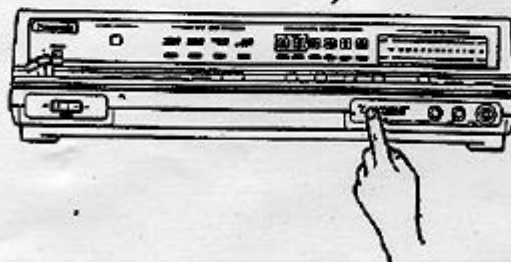

SPECIFICATIONS

Source Input:	X2 (SOURCE 1 and SOURCE 2)
Video Input:	1.0 Vp-p/75 ohms or high impedance loop-through, PAL composite signal, BNC connectors
Audio Input:	-10 dBV/15 kohms, pin jacks (Left and Right)
External Camera Input:	1.0 Vp-p/75 ohms CCIR or PAL composite signal, BNC connector X 1
Sync Output:	1.0 Vp-p/75 ohms, composite sync, BNC connector X 1
Recording Output:	X2 (REC OUT 1 and REC OUT 2)
Video Output:	1.0 Vp-p/75 ohms, PAL composite signal, BNC connectors
Audio Output:	-8 dBV/1 kohms, pin jacks (Left and Right)
Preview Video Output:	1.0 Vp-p/75 ohms, PAL composite signal, BNC connector X 1
External Sound Input:	
MIC Input (mono):	-60dB/600 ohms, unbalanced, tip-ring-sleeve type phono jack X 1
AUX Input:	-10 dBV/15 kohms, pin jacks (Left and Right)
Headphone Output:	-30 dB/8 ohms, (8 ohms — 100 ohms), tip-ring-sleeve type phono jack X 1
Character (TITLE) Input:	10-pin connector X 1 for optional Character Generator WV-KB12
Effects	
Video:	Still, Strobe, Mosaic, Paint, Mix, Wipe, Superimpose, Fade-in/out
Audio:	Mix, Fade
Back Colours:	White, Yellow, Cyan, Green, Magenta, Red, Blue, Black
Wipe Patterns:	Circle and Square with positioning, and 15 additional patterns without positioning
Wipe Positioner:	Built-in Joystick Positioner
Input Video Frequency Range:	Sync: 15,625 kHz \pm 300 Hz, SC: 4.433619 MHz \pm 40 Hz
Frequency Response:	3 MHz (-3 dB) (Video, Y signal), 20 — 20 kHz (-3 dB) (Audio)
Maximum Resolution:	300 lines
Gain:	Unity (Video)
Signal-to-noise Ratio:	More than 46 dB (Video), 50 dB (Audio)
Differential Gain:	\pm 10%
	and WJ-MX10/G
Power Consumption:	35 W
Ambient Temperature:	0° — 40° C
Ambient Humidity:	Less than 90%
Dimensions:	420 (W) X 100 (H) X 327 (D) mm
Weight:	5.5kg

Weight and dimensions indicated are approximate.
Specifications are subject to change without notice.

STANDARD ACCESSORIES

- Mounting Base for Character Generator WV-KB12

OPTIONAL ACCESSORIES

- Character Generator WV-KB12